

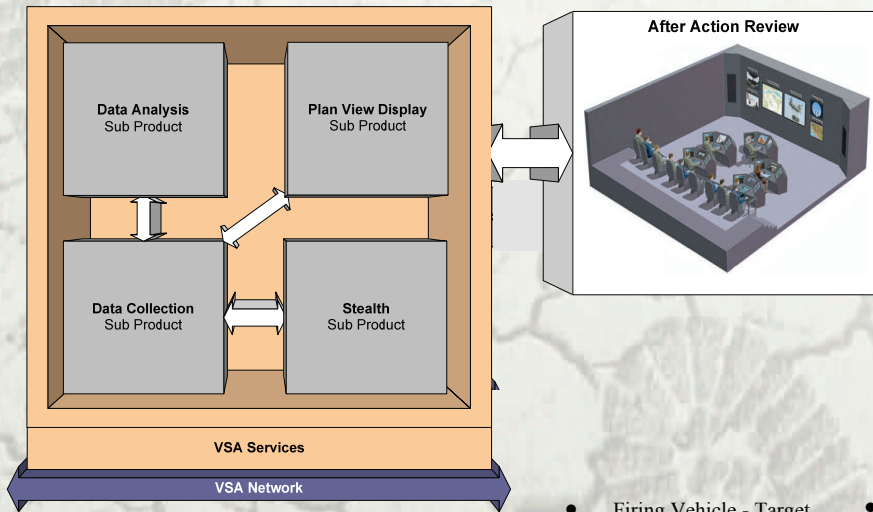

# AAR CVC Fact Sheet

After Action Review



## Benefits

- Platform independent
- Open source implementation
  - Framework for Linux-based enhanced reporting and data mining
  - SQL Database (maintainability & extensibility)
- Extensive graphical report generation capability
- Playback while recording
- Dynamic report modification
- Ability to generate multiple reports at the same time
- Java based GUI's (maintainability & extensibility)

## Reports

- Firing Vehicle - Target Scoreboard
- Field of View
- Direct Fire
- Indirect Fire
- Weapon/Ammunition/Kill Crosswalk
- Ammunition Expenditure
- Minefields
- Close Air Support
- Damage
- Personnel Casualties
- Total Tank & PC Kills
- Total Truck & Troop Kills
- Total Helo Kills

## Capabilities

- Provide real-time monitoring, recall and replay (record / playback) of the training exercise
- Provide control and processing for capture, storage and playback of exercise track files and analysis data
- Provide automated analysis of exercise training data and trainee performance metrics during or after the exercise
- Provide report generation and debrief construction / control / presentation capabilities
- Provide control console capabilities for the AAR node
- Provide a 3D visualization of the battlespace

### Future Capabilities

PVD, Sound System, Comms System, Audio Video Collection

## Reuse Options

- Support as standalone functionality for individual capability (i.e. Stealth)
- Support replacement for existing simulation specific system component functionality
- Support integration as a product into existing architectures

### Distribution Process

Software distribution of products shall be made by the PM CATT Post Production Software Support (PPSS) Lab, upon receipt and approval of the request that was made through the SE Core portal.

## Planned Adopters

- CCTT
- Data Collection & Data Analysis sub-products
- FCS TCC

## Potential Future Adopters

- Stryker
- AGTS

## Documentation

Component Contract includes:

- Requirements Specifications
- SDD
- Interface Definition
- Build Procedures
- Install Procedures
- Runtime Procedures
- Training Material
- User Manual

- **Enhanced AAR Experience for the Warfighter (Playback and Take home reports)**
- **Enhanced AAR Experience for the Operator (GUIs, configurability)**
- **Easy to adopt and integrate**
- **Minimize LCC while providing added capability to Warfighter training**